

TracSPORTer

STANDARD & XW MODEL

FOR OVER 24 YEARS WE HAVE PRIDED OURSELVES IN PRODUCING PREMIER QUALITY VEHICLE TRANSPORTERS FOR ALL KINDS OF USES - WHETHER IT BE A BASIC FIXED BED UNIT OR A FULLY ENCLOSED 'PROSPORTER'. WITH A DESIGN AND SAFETY TEST STANDARD THE ENVY OF THE INDUSTRY, OUR HIGHLY EXPERIENCED TEAM OF DESIGN ENGINEERS WILL BE HAPPY TO DISCUSS YOUR VEHICLE TRANSPORTER SPECIAL REQUIREMENTS.

TRACSPORTER STANDARD & XW

FULLY ENCLOSED SUPER AERODYNAMIC ONE PIECE MOULDED COVER GIVING HIGH SECURITY COMBINED WITH EASY ACCESS, SOUND QUALITY CONSTRUCTION AND TOTAL RELIABILITY. IDEAL TO CARRY ALL TYPES OF CARS FROM VINTAGE TO MODERN DAY RACE CARS IN STYLE AND SAFETY WITH THE ADDED BONUS OF WEATHERPROOF COVER AT RACE MEETINGS AND EVENTS. THE TRACSPORTER RANGE CAN ALSO BE USED AS GARAGE ACCOMMODATION MAKING IT POSSIBLE TO STORE THAT EXTRA CAR.

SLEEK ONE PIECE GELCOAT MAINTENANCE FREE BODY, DROP DOWN REAR DOOR / LOADING RAMP WITH GAS SPRING ASSISTANCE AND FULL ANTI-SLIP REAR DOOR PANEL, STYLISH ONE PIECE MOULDED BOLT ON MUDGUARDS, EASY TO LOAD WITH EXTREMELY SHALLOW LOADING ANGLE, FULLY GALVANISED CHASSIS, BPW HIGH QUALITY RUNNING GEAR, AUTO REVERSE BRAKING TO ALL WHEELS, TWO SPEED MANUAL WINCH, SPARE WHEEL AND TYRE, MULTIPLE TIE DOWN POINTS, HIGH QUALITY LIGHTING SYSTEM WITH HIGH LEVEL BRAKE LIGHT AND A 5 YEAR CHASSIS WARRANTY.

TRACSPORTER XW

THE TRACSPORTER XW HAS BEEN PRODUCED FOLLOWING DEMAND FOR A TRACSPORTER THAT FEATURES THE FOLLOWING AS STANDARD - LARGE GULL WING DOORS FITTED TO BOTH N/S & O/S, LONGER & WIDER BED AND FRONT TIE DOWN HATCHES FITTED TO N/S & O/S. THIS MAKES THE XW EXTREMELY VERSATILE, OFFERING MANY OF THE ADVANTAGES OF MORE EXPENSIVE COVERED TRAILERS. ALONGSIDE THESE ADVANTAGES, THE TRACSPORTER XW RETAINS ALL THE WELL PROVEN FEATURES OF THE STANDARD TRACSPORTER.

NEW FOR 2014

THE TRACSPORTER HAS BEEN UPGRADED FOR 2014 WITH A FULL WIDTH ANTI-SLIP REAR DOOR SURFACE, PLUS A TOTALLY FLAT LOADING AREA.

	TRACSPORTER	TRACSPORTER XW
BODY SIZE INC FRONT OVERHANG (A1)	14'10" (4.52m) X 6'1" (1.85m)	16'9" (5.1m) x 6'6" (1.98m)
BED LENGTH (A)	14'2" (4.32m)	16' (4.88m)
BED WIDTH (B)	6'1" (1.85m)	6'6" (1.98m)
OVERALL LENGTH (C)	18'4" (5.75m)	21' (6.39m)
OVERALL WIDTH (D)	7'7" (2.3m)	7'10" (2.39m)
HEIGHT (E) Floor to bed	16" (0.40m)	15" (0.38m)
HEIGHT (F) Floor to highest point	7' (2.14m)	7'5" (2.26m)
HEIGHT (G) Through the door	5' 5" (1.66m)	5' 7" (1.71m)
GROSS WEIGHT	2000 / 2600 Kg's	2700 Kg's
LOAD CAPACITY	1220 / 1800 Kg's	1700 Kg's

TRACSPORTER & TRACSPORTER XW
OPTIONAL EXTRAS AVAILABLE:

- TYRE RACK
- STARTER RAMPS
- ELECTRIC WINCH
- REAR SUPPORT STANDS
- UNDER FLOOR STORAGE
- HYDRAULIC TILT BED OPTION
- BATTERY POWER PACK (FOR WINCH)
- CUSTOM GEL COAT / PAINT COLOUR FINISHES

MORE OPTIONS AVAILABLE PLEASE SEE FULL OPTIONS LIST

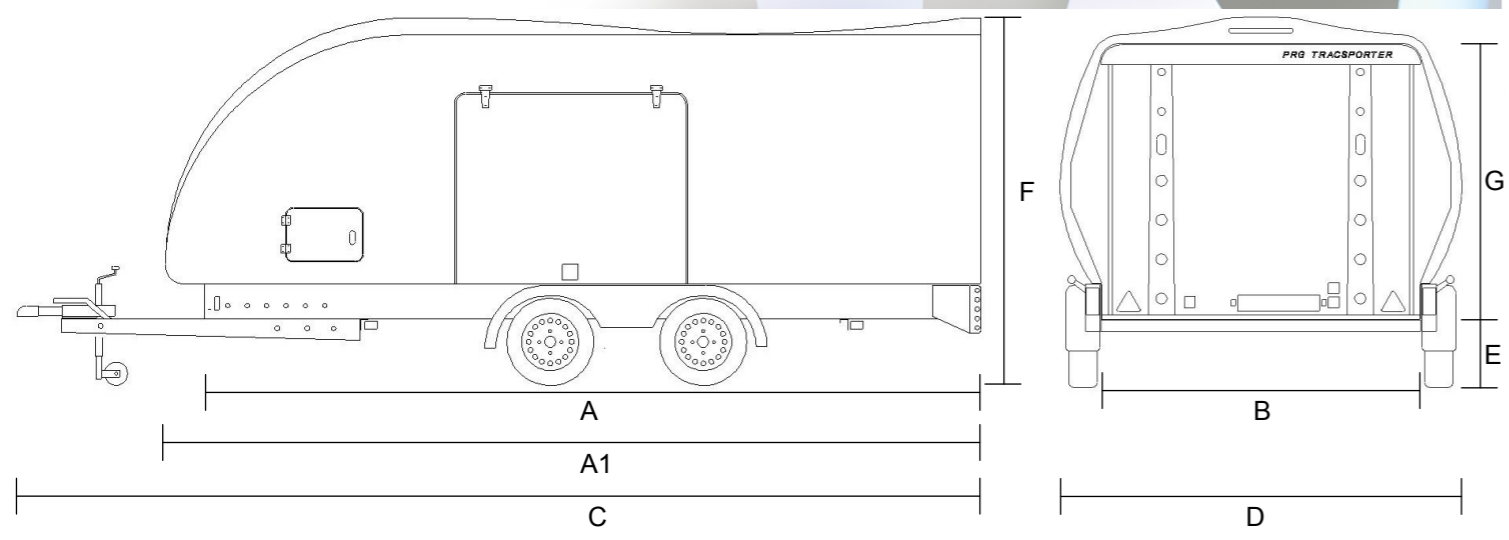

TracSPORTer

STANDARD & XW MODEL

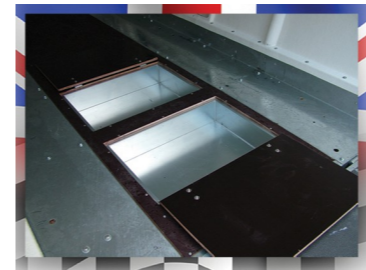

Under floor storage systems to manage all the available space within your TracSPORTer.



Flat level floor with the latest anti-slip rear door panel to aid loading with maximum grip



Gull-wing doors fitted as standard on the XW model, designed with integral moulded door frame to give a sealed professional door opening.



Hydraulic tilt bed operation with dual action hand pump, allowing the shallowest loading angles on the market. We also have an electric tilt bed option.



PRG TRAILERS LTD | LIGHTWOOD GREEN | AUDLEM | CREWE | CHESHIRE | UNITED KINGDOM
TEL: +44(0)1270 812402 | FAX: +44(0)1270 811293 | www.prgtrailers.co.uk | E-MAIL: info@prgtrailers.co.uk

Standard colour finish is white, PRG offer a wide choice in finishes from gel colour through to metallic paint and custom graphics. Please ask for details



Lowest loading angle on the market



Winterhoff safety coupling for the ultimate connection between trailer and tow vehicle

Optional independent shock absorbers to give a softer ride, when fitted in conjunction with the Winterhoff safety coupling you can tow at 120KPH through several European countries



Hydraulic 2nd deck within TracSporter



Heavy duty auto-flip jockey wheel

TracSporter

Aerodynamically designed to give superb stability when towing

One piece rear door & ramp, with steel edge support



Optional LED internal strip & rear loading lights

